



# INSTALLATION GUIDE

## **BBT054/ BBCD054 BBA054 /BBT054-NL**

FORD RANGER MkII / EVEREST 7/2015 **with** Tech Pack

## **BBC055/ BBCD055**

FORD RANGER / EVEREST Mk II and Mk III 7/2015 **without** Tech Pack



- Ironman 4x4 BBT/ BBCD/ BBA054 Bull Bars fit to a Ford Ranger Mk II / Everest **with** Tech Pack.
- Ironman 4x4 BBC055/ BBCD055 Bull Bars fit to a Ford Ranger / Everest **without** Tech Pack.
- It will take about 4 hours to install.

**NOTE: This product has been tested for air bag compatibility and therefore the mounting system MUST NOT be modified**

**IMPORTANT:** Bull Bar installations should only be done by a qualified person and it is the responsibility of this person to ensure correct fitment.

1. Before installation check bull bar application is compatible with your vehicle.

Before making any cuts, please refer to bumper cutting instructions applicable to your vehicle model (Ford PX Ranger Mk II 7/2015+).

2. Use bodyline on bumper and grill as reference to mark cut line on assembly as shown.

**Ford Ranger Px II**



**Ford Ranger Px III *WITHOUT* Tech Pack**



Position cutting template in place under headlight and align with guard edge and grill line.



3. Remove grill and bumper bar assembly.

Cut bumper and grill assembly along marked line. Use an air hacksaw or similar to remove the lower section of the bumper bar.



4. Remove parking sensors from bumper and retain for refitment later.

Disconnect and remove Adaptive Cruise Control from metal bumper support.



5. Remove plastic insulators and discard.



6. Temporarily re-fit top section of bumper bar (cut in previous step) to vehicle. Using end of bumper bar as a guide, mark cut lines onto plastic bumper support brackets.



7. Remove bumper and plastic bumper support brackets. Cut along marked line as shown.



8. Mask lower edge of guard and paint lower section satin black as shown.



9. Re-fit plastic bumper bar support brackets as shown.



10. Remove air duct shields as shown. Disconnect temperature sensor from passenger side before removing.

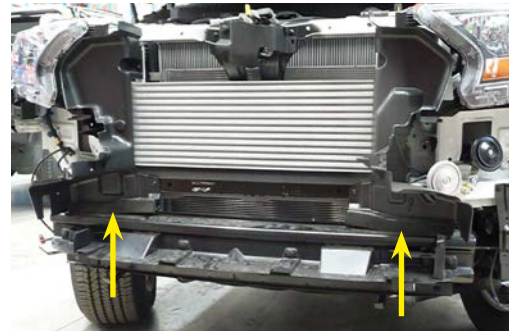

11. Mark up cut lines on passenger side of air duct shields following the edges and contours of the shield as shown in pic A.



Repeat the process for the drivers side as shown in pic B.

Re-fit modified air duct shields, remembering to re-connect temperature sensor to passenger side.

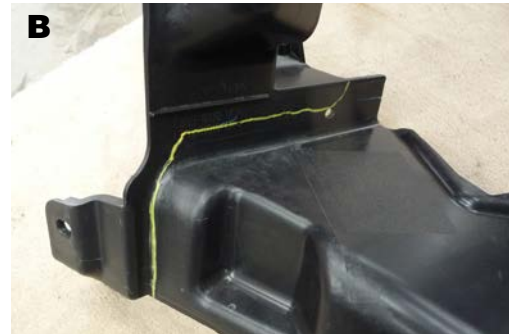

12. Install chassis bracket as shown using hardware provided.



13. Using chassis bracket as a guide, drill a 12.5mm hole each side through chassis and install bolts, flatwashers, spring washers and nuts as shown.



14. If winch is being installed, refer to winch installation instructions from page 8.

15. Re-fit bumper bar and grill assembly.



16. Unwrap bull bar. Check over riders and light assemblies are tight in bull bar before installation.

17. Remove Bezel from parking sensors and attach sensors to bull bar using clamping plate and Nyloc nuts supplied.

Note: When securing sensors in position, nuts only need to be nipped up. Any tension on sensor will cause them to malfunction. **DO NOT OVER TIGHTEN NYLOC NUT**

18. Install Adaptive Cruise Control sensor to bracket on bullbar sandwiching the protective cover (supplied) between the sensor and the opening in the face of the bullbar using M8 hardware provided.



19. Fit bull bar to chassis brackets using M12 bolts, flat washers, spring washers and nuts provided.

20. Align bull bar with vehicle leaving a 10mm gap between bullbar wing and mudguard. Tighten all bolts.



21. Once bar is aligned with vehicle and tightened drill through pinning holes between bull bar and chassis bracket and secure with bolts, washers and nuts provided.

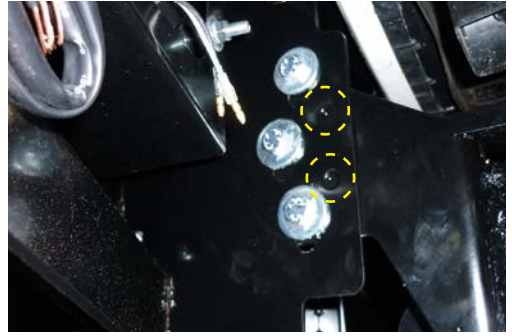

22. Connect parking sensors, Active Cruise Control, park lights, indicators and fog lights as per wiring diagram at the back of these fitting instructions

23. Fit protection plates to underneath of bull bar using M8 bolts, spring washers and flat washers provided.



24. Disconnect and remove keyless entry antenna from rear of drivers side guard liner base as shown in pic A. Trim guard liners using protection plates as a guide.

Align top bolt hole of keyless entry antenna with existing bolt hole in guard liner and reattach with double sided tape higher up on the guard liner.

Reattach guard liners to protection plates using clips provided, see pic B.

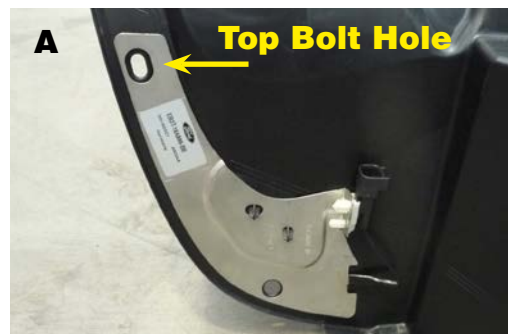

# Winch Installation

## FOR RANGER MKII / EVEREST ONLY

Grill and bumper will need to be modified as shown in the 6 images below.





# Winch Installation

1. Bolt winch to cradle with gearbox to the left hand side of vehicle and cable spooling from bottom of the cable drum using bolts and washers provided.



2. Bolt fairlead to recess in front of bull bar using bolts, washers and nuts provided.



3. Fit bull bar to vehicle referring to steps 12 - 17 of bull bar fitting instructions.

4. Mount control box in desired location.



5. Connect three colour coded cables to the corresponding poles on winch motor.



6. Connect the thin black earth wire and negative battery cable to the earth connection on the opposite side of winch motor.



7. Run the positive and negative battery cables into the engine bay taking care to secure cables away from any sharp or moving objects.

8. Connect positive and negative battery cables main battery of vehicle (Not Auxilliary Battery).

9. Attach breather hose to barb fitting on winch motor. Run hose to the highest available point in engine bay and cable tie in position. Cable tie hose away from any sharp, hot or moving objects.



# Wiring Diagrams

## PARK LIGHT & INDICATOR

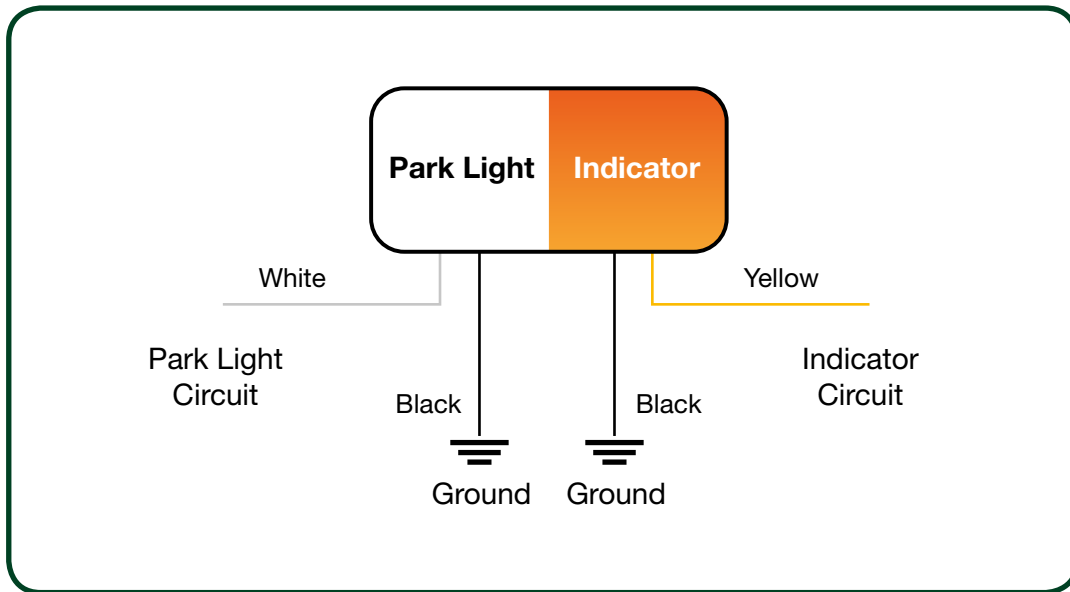

## FOG LIGHTS

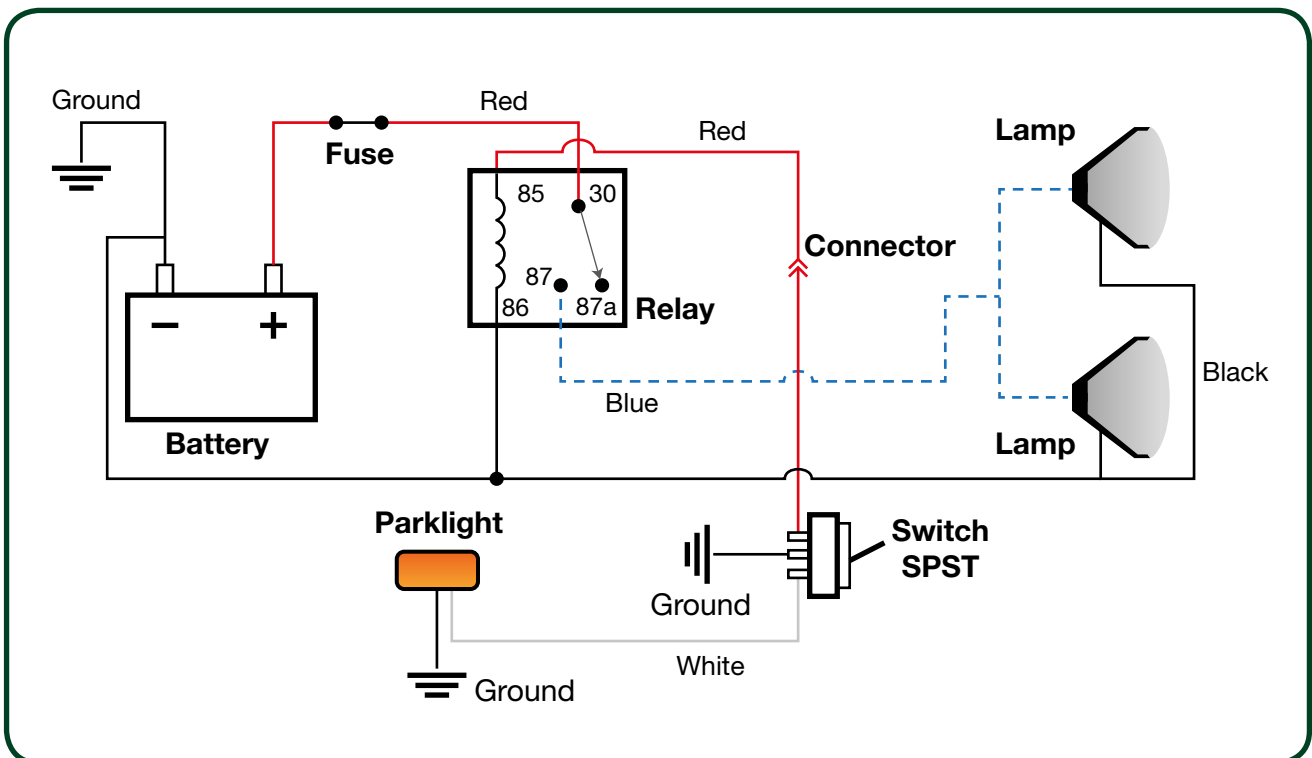

Registration Point



Registration Point

**UNDER HEADLIGHT**

Registration Point



Registration Point



**FORD PX RANGER MK II and UA EVEREST (Only)**

**BBA054 / BBCD054 / BBT054**

**BBC055 / BBCD055 BULL BAR TEMPLATE**

**GUARD**

**CUT LINE**



**UNDER HEADLIGHT**

**GRILL**



**FORD PX RANGER MK II and UA EVEREST (Only)  
BBA054 / BBCD054 / BBT054  
BBC055 / BBCD055 BULL BAR TEMPLATE**

**090218**